

19" SOUNDproof



Fit to Environment



Very Silent



SOUNDproof Free Standing Cabinets

General Concept;

SOUNDproof Free Standing cabinets are designed to perform for the absorption of the created noise from the active equipments housed inside the cabinet. While performing a Sound reduction around the cabinet, with a Wooden Concept finish fits to the office environment perfectly.

The product is designed with W750mm width and D1130mm depth allowing all needs of Data Network Cabling applications, Server and Storage applications.

Mostly in office environment, due to created noise levels from enclosure, the people in offices getting annoyed, stressed, which is effecting performance of people, while there is limitations with the occupational health and safety rules.

Funny things happens in offices in some cases, all of a sudden a Fan Unit or an active device Switched off by an office boy or a personnel. Than the network stops, servers are heated.

Thus; the product range is developed for various offices, banks, hospitals, laboratories, hotels, meeting rooms, conference saloons, with a superior sound reduction performance.

The product is equipped with the most Silent Fan and Ventilation system, max 29-30dB levels, to support the main activity of noise reduction performance.

The product is available in 3 heights as 17U, 32U and 42U sizes with W:750mm and D:1130mm. Each cabinet is supplied as standard with a Wood Concept finish on front and top, steel rear door and side panels, front and rear are lockable.

SOUNDproof series have a professional technical but aesthetic look with decorative wood finish on the front door and roof structure; the product range attracts the attention with the mostly environmentally fit and selected color RAL 9005 Black with fine wrinkle soft touch paint.

Completely standard and stocked product portfolio, being delivered as single piece assembled product, as shipping configuration the adjustable feet group, Heavy Duty Castor Set and H70mm Modular Plinth are included.

SOUNDproof series product range with optimal panel mounting size, and a variety range of accesories enclose the whole expectation of users.



CONSTRUCTION DETAILS:

Main Frames;

Multi Folded Automated Bending technology applied monoblock side panel/frame system, provides a heavy duty structure results to high load capacity of: 1000 kgs.

Monoblock multi folded top and bottom cases, tightly fixed to the side panel/frame system with fixing hardware , fully modular system generated.

Cable Entry;

Bottom case integrated with Wide cable entry point provides maximum versatility. The rubber edged sliding mechanism on the cable entry point at bottom with $w=350\text{mm} \times d=250\text{mm}$ allows large cabling infrastructure applications. On rubber edged sliding mechanism max cable entry opening is $w=350\text{mm} \times d=150\text{mm}$. After inserting the cables, the rubber edged mechanism holds and fixes the cables in parallel preventing the cabinet from dust entry.

Front Door (Melamine Coated Chipboard);

Front Door , Wardrobe Style Double Opening, 18mm Thickness, Melamine Coated Chipboard, with integrated Barrel locking mechanism on top.

Rear Door (Solid Metal);

Rear Door, is Double Skin, Metal, Sound emitting isolation material on the surface of both skins, integrated with Handled Locking Unit.

Rear Door is also carrying a 3 Way Fan Module integration area, while the hot air exhaust openings are available in both left and right sides of the rear door.

FAN Module Integration Capacities per U height;

- 17U Rear door, has 1x3 Way Thermostat Controlled Integrated Fan Module, with 2 pcs hot air exhaust openings included in shipping configuration.

- 32U Rear door, has 2x3 Way Thermostat Controlled Integrated Fan Module, with 4 pcs hot air exhaust openings included in shipping configuration.

- 42U Rear door, has 3x3 Way Thermostat Controlled Integrated Fan Module, with 6 pcs hot air exhaust openings included in shipping configuration.



19" SOUNDproof Cabinets / W:750mm D:1130mm

CONSTRUCTION DETAILS:

Side Panels;

There are narrow side panels, which are lockable and removable with barrel locking. Single Skin Narrow Side Panels are also covered with Sound emitting isolation material. From narrow door, an access to vertical PDU housing is possible.

There are wide side panels, which are main frame function of the enclosure which are double skin. Both skins of the panel are covered with Sound emitting isolation material.

PDU Integration and capacities per U height;

17U cabinet, has at both sides a 19" PDU vertical assembly location.

32U cabinet, has at both sides 2pcs 19" PDU vertical assembly location. And a 32U vertical PDU can be housed.

42U cabinet, has at both sides 2pcs 19" PDU vertical assembly location. And a 42U vertical PDU can be housed.

All of those PDU assembly to cabinet is vertically where 0U rack space occupied. Even tough any 19" standard PDU can be assembled at the 19" rails.

19" Mounting Rails;

19" rails of SOUNDproof Series Free Standing cabinets are with automated silk-screen U numbering, depends on size 1U to 42U, same from top to bottom or bottom to top results to same U height selection. No matter from where you have started counting. 19" rails are 4 fold bending surfaces, 2,0mm thickness provides the high load capacities. The 19" rails are made of steel with 8-12 micron zinc plating for corrosion resistance. 19" rails are adjustable in depth.

Vertical Cable Management Panels, and brushed cable passage in Front;

Ready Vertical Cable Management Panel all height in front 1set=2pcs left / right is in shipping configuration. Vertical Cable Management Panels allows better cable management with integrated Aluminium rings 88x60mm, also there is 70x145mm brushed cable passage openings in between the rings to pull the cable bundles to the rear side of the cabinet.

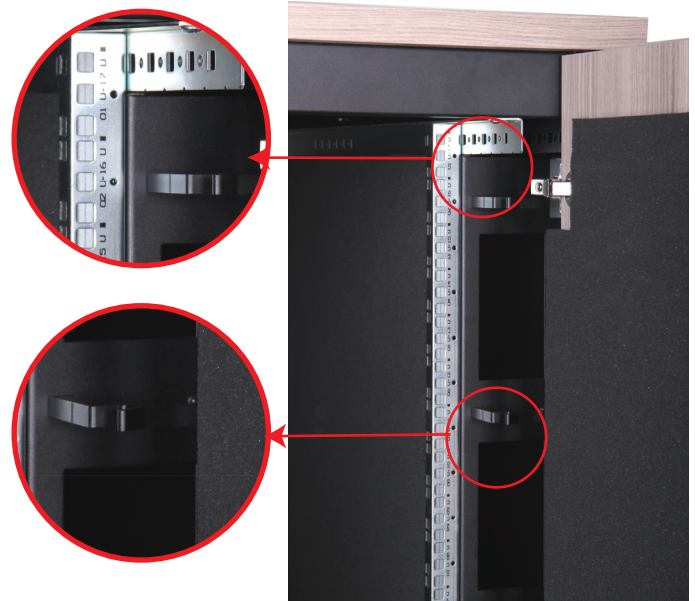

19" SOUNDproof Cabinets / W:750mm D:1130mm

CONSTRUCTION DETAILS:

Top Cover;
Top Wood Concept cover is 30mm thickness, Melamine coated Chipboard material gives a better fit to the office environment.

Top Cover is fixed from inside the cabinet, can not be detached from outside, fully secure and sturdy.

In parallel helps to have a furniture perception.
Any kind of office tools, equipments, like Photocopier, printers, or folder boxes , book shelves positioned on top.

Plinth, Leveling Feet Group, Caster Set;
The SOUNDproof cabinet equipped with heavy duty caster set, leveling Feet Group, as well 70mm high already integrated Plinth.

Once the leveling feet functioned, the castors will come off, and final structured cabinet in its place will securely positioned.

Caster and Leveling feet groups are totally recessed, so would not be seen outside

Melamine Coated Chipboard;

The material can be selected from offered options as below:
O-Oak, C-Cherry, B-Beech, T-Teak, W-Walnut,M-Maple
(Maple is standard stock chipboard option)

EN 14322; Wood-based panels. Melamine faced boards for interior uses. Definition, requirements and classification; E1 quality level, Formaldehyde Emmision E1 level, European Standard, classified as non Toxic. Indoor air concentration is less than 0,1 ppm (parts per million)



Maple
(M)



Teak
(T)



Walnut
(W)



Oak
(O)



Cherry
(C)



Beech
(B)

19" SOUNDproof Cabinets / W:750mm D:1130mm

CONSTRUCTION DETAILS:

Sound Emitting Isolation Material;
 High Density Sound Emitting material, in medium, high and low frequency segments, flexy type with most well ventilation allowance hole spacing allows for best sound emitting performance.

- 75-100 kg/m³
- Non Flammable; (BS 476 Part 6 Class 0, Part 7 Class 1)
- Hallogen Free
- Anti-Fungus
- For acoustic and sound emitting applications

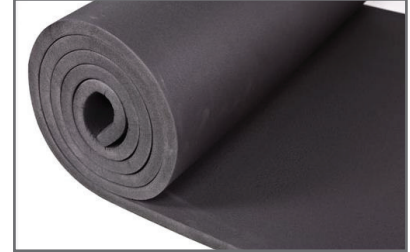

Covered all doors and panels, in between the double skins, and internal side of the inner skins.

Sound Emitting Performance;

8 Servers in a Standard Cabinet

8 Servers in a SOUNDproof Cabinet

8 Servers in a Standard Cabinet			8 Servers in a SOUNDproof Cabinet		
70dB			Sound Level of Vertical Driller		70dB
60dB			Normal Speech noise levels face to face		60dB
55dB					
			office background noise level		
50dB					50dB
			SOUNDproof Cabinet		
40dB Silent Room					40dB Silent Room

18-21 dB noise level reduction from 1 meter distance to the enclosure

All design features provide you strength and 4 way access to your enclosure and equipments, easy to reach to enclosure and equipments for all infrastucture installations and maintenance needs. Also to function with the intend of having a super-fit in environment while providing the best sound emitting performance...

Lock, Plinth, Cable Entry, Castor Set, Leveling Feet, Hot Air Exhaust

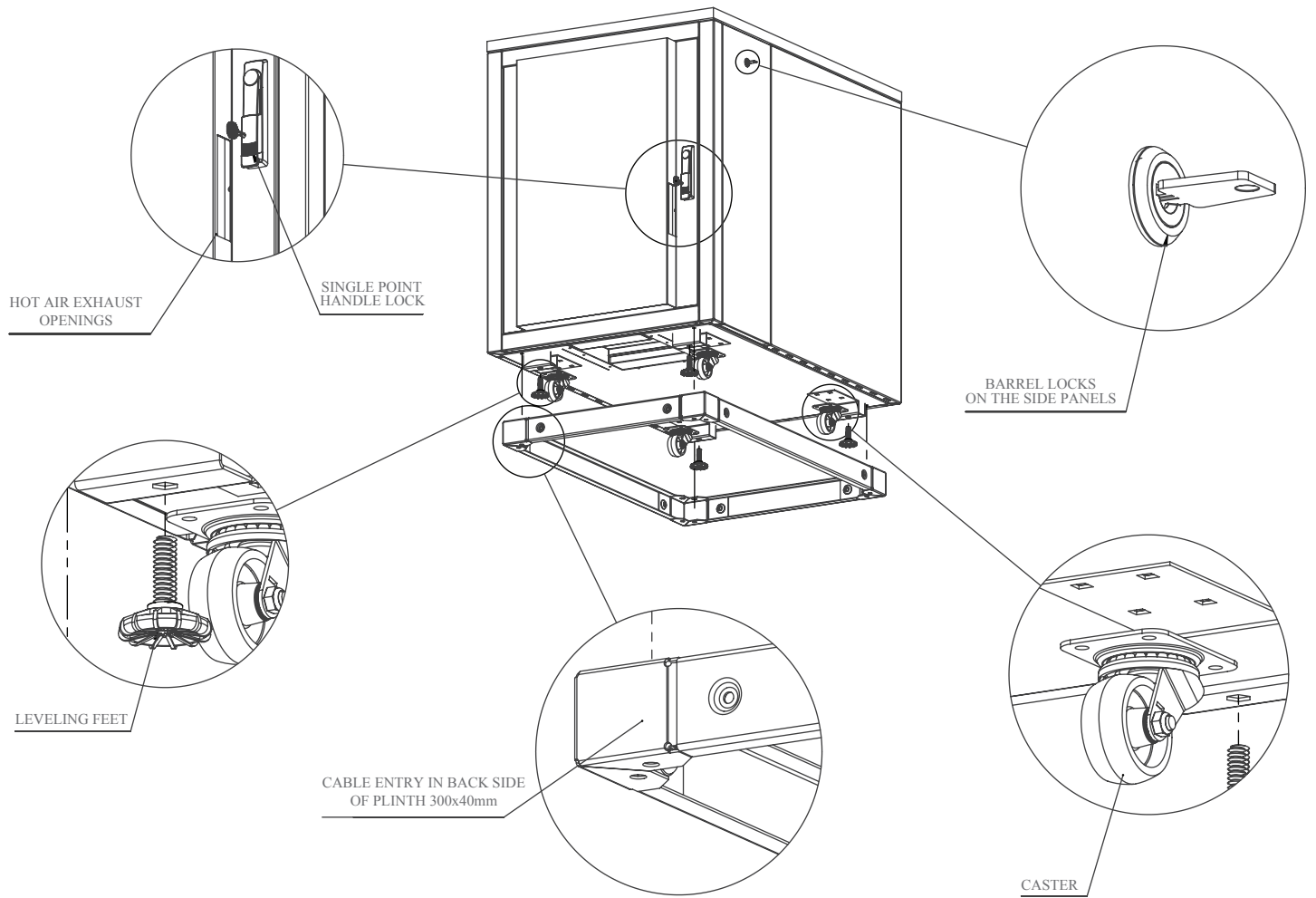

19" SOUNDproof Cabinets / Concept Drawings

Fan System, Cable Passage brushes, Cable management Rings

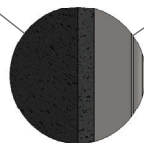
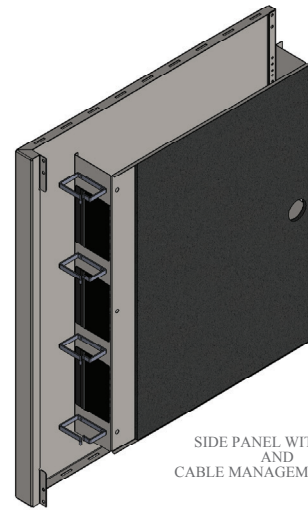
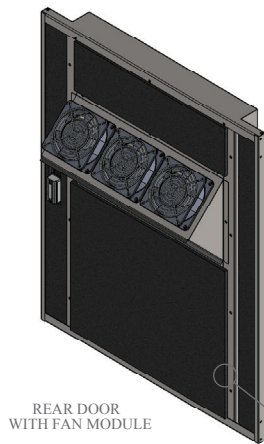

CABINET (U) HEIGHTS	FAN MODULES	PIECE
17U		1
32U		2
42U		3

CABINET (U) HEIGHTS	CABLE RINGS	PIECE	CABLE PASSAGE BRUSHES	PIECE
17U		4+4		3+3
32U		7+7		6+6
42U		9+9		8+8

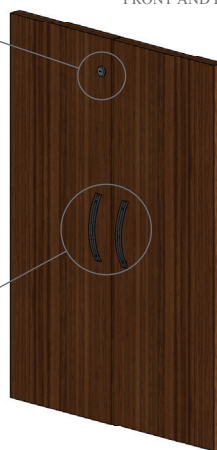
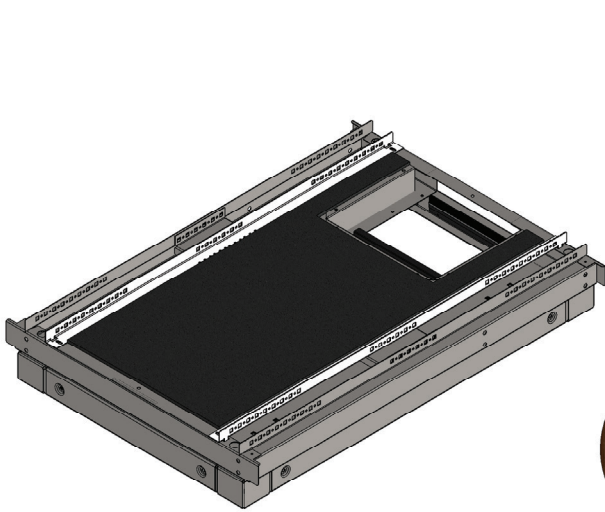

HINGES WITH HYDRAULIC BRAKES AT FRONT DOORS

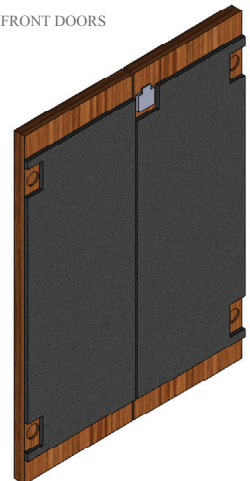

19" SOUNDproof Free Standing Cabinets

Width: 750 mm.
Depth: 1130 mm.

Width=750mm
Depth=1130mm

Standard Heights:

3 different U heights: 17U, 32U, and 42U

Standards, and Compliances:



ISO 9001:2008
Quality Management System

EN 61587 -1:2012
Mechanical Structures for
Electronic Equipment

IEC 297-1, 19" mounting
IEC 297-2 Overall cabinet dimentions



CE conform to
EN 60950-1:2006
Information Technology
Equipment – Safety – Part-1-
General Requirement



UL listed to
UL 2416, Outline of Investigation for
Audio/Video, Information and
Communication Technology Equipment
Cabinet, Enclosure and Rack Systems;
UL 60950-1 and CSA C22.2 NO.
60950-1-07, Information Technology
Equipment Safety Part 1: General
Requirements



Environment Friendly;
* ISO 14001 Environmental
Management System
* RoHS compliancy
* %100 Recyclable Material

Load Capacity: 1000 kgs.



SOUNDproof Free Standing Cabinets, with 19" w:750mm and d:1130mm physical sizes, with max internal usable depth, and 3 different height, gives a wide selection chart for users.

Standard Color of Metal Parts:

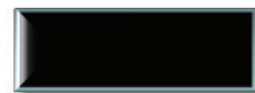

RAL 9005 Black



DRAWINGS

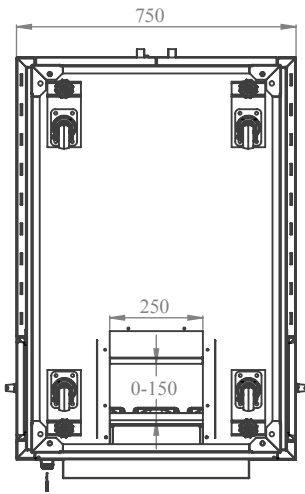

BOTTOM VIEW

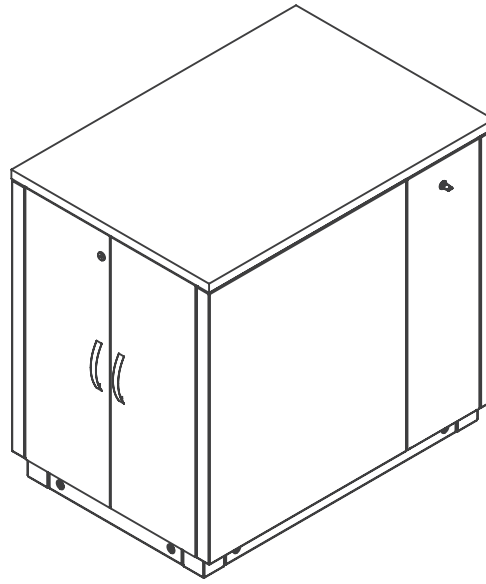

ISOMETRIC VIEW

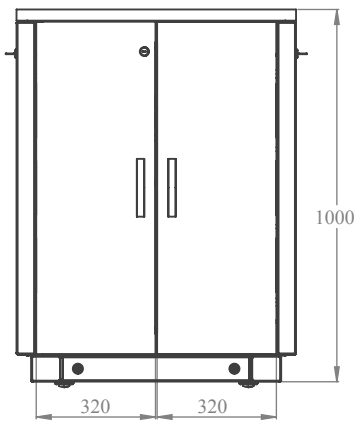

FRONT VIEW

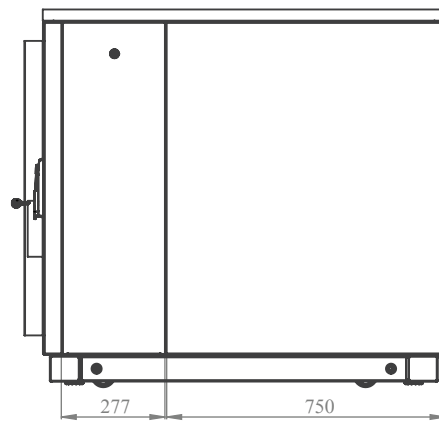

SIDE VIEW

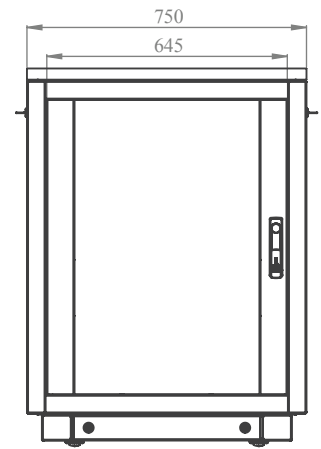

REAR VIEW

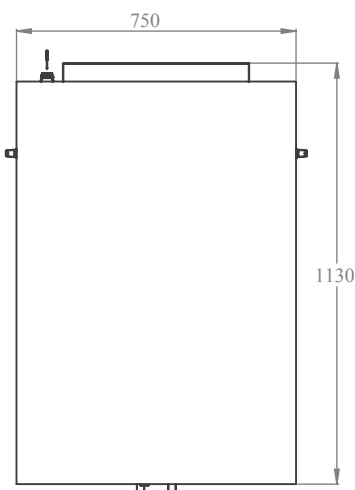

TOP VIEW

DRAWINGS

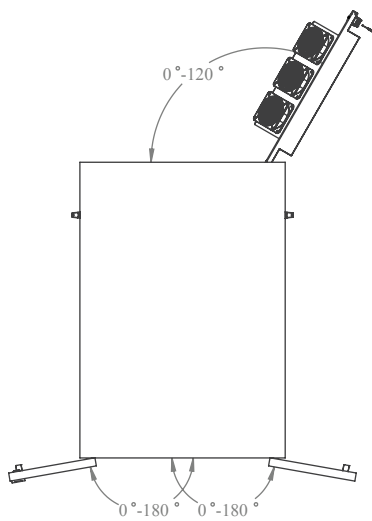
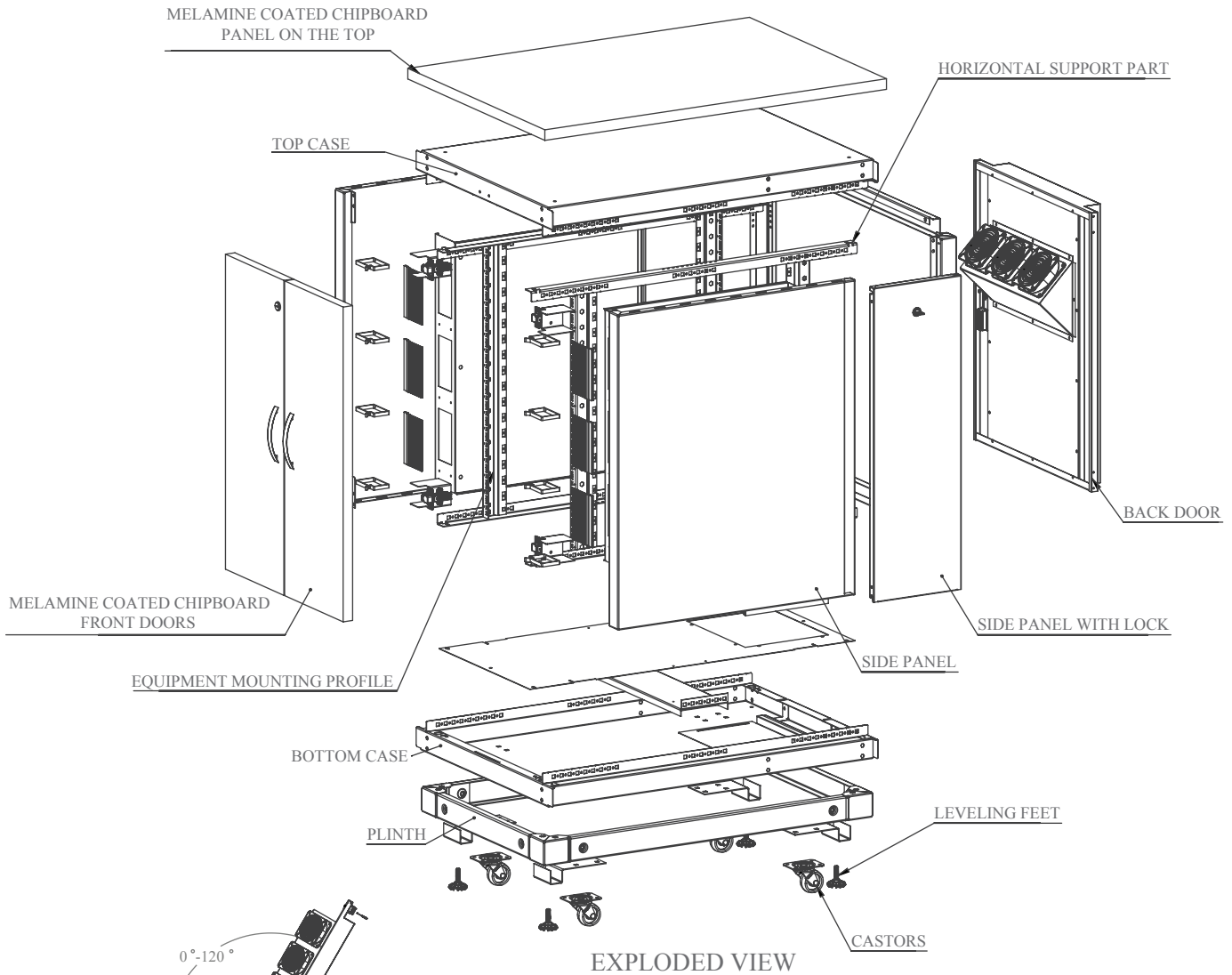

FRONT DOOR OPENING ANGLE

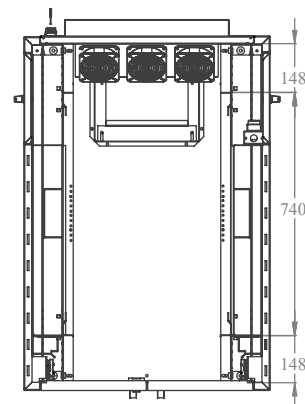

EQUIPMENT MOUNTING DISTANCE

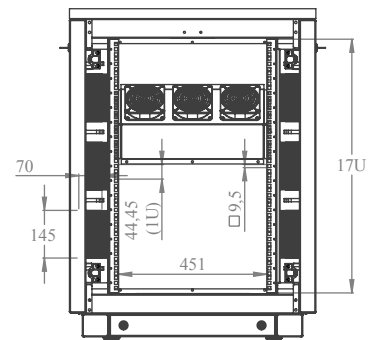

DIMENSIONS IN WIDTH AND HEIGHT

DRAWINGS

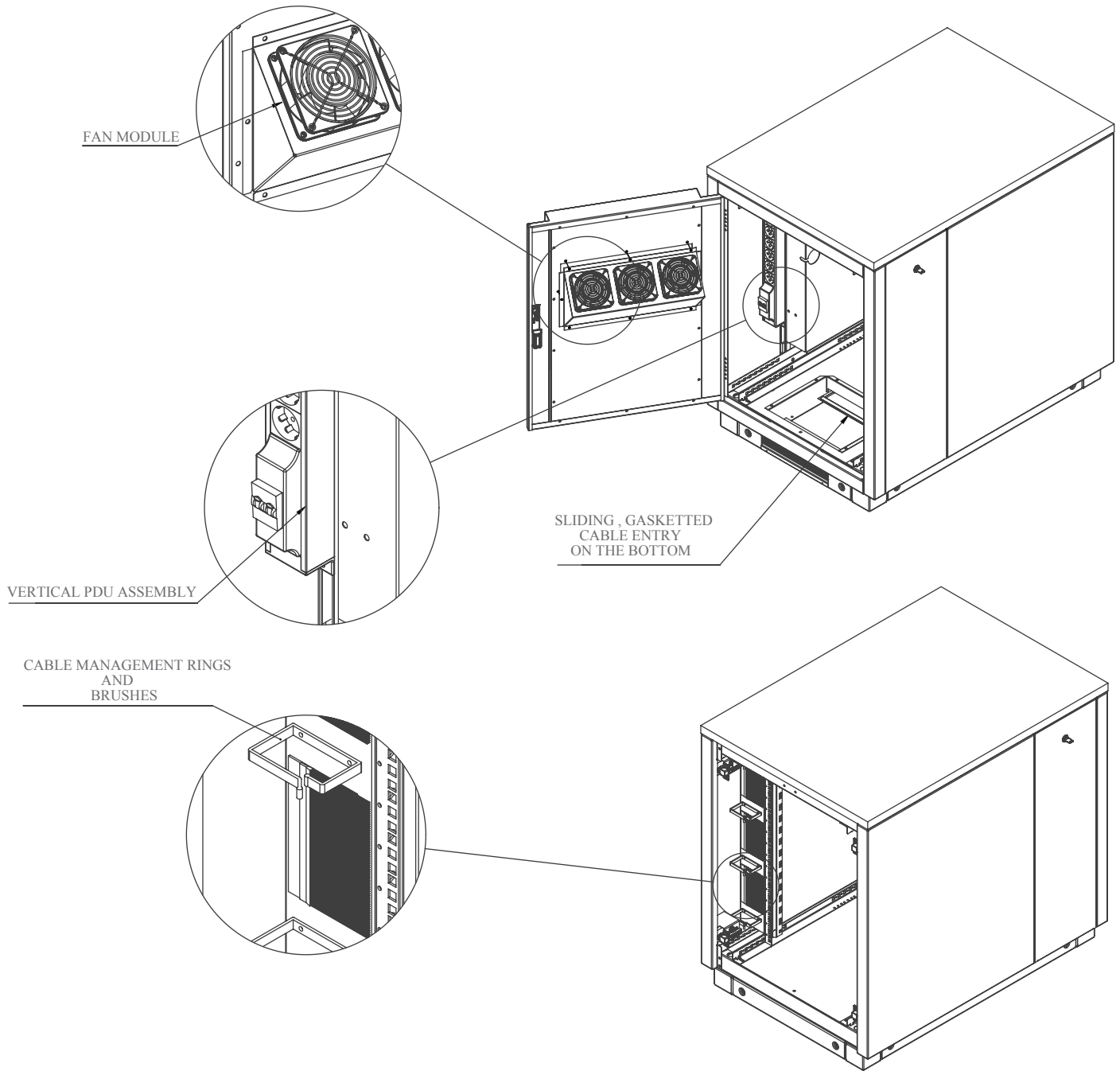

SOUNDproof Series Free Standing 19" Cabinets 17U W=750mm D=1130mm

Product Number	Product Description	Size WxDxH mm	h size in U	h in mm	H mm, overall incl feet, castor and plinth	Width Overall mm	Width Rail to Rail	Depth Overall mm	Depth Shipping Conf. Rail to Rail mm	QTY IN PACKAGE	PACKING DIMENSIONS WxDxH mm	Standard NET Weight of product kgs	Gross Weight of Product kgs	QTY IN PALLETTE
LN-SP-17U7511-M-BL	17U 19" SOUNDproof Cabinet W=750mm D=1130mm	750x1130x1000	17U	756	1000	750	19"	1130	740	1	820x1200x1120	138	152	1

* Standard supply is with M-Maple Wood / Furniture Concept

** Incase Requested with any other Wood/Furniture Concept , replace M with, O-Oak, C-Cherry,B- Beech, T-Teak, W-Walnut, based on your selection

*** All Metallic Parts are in RAL 9005 Black Color, any other color requests, please have a correspondence.

DRAWINGS

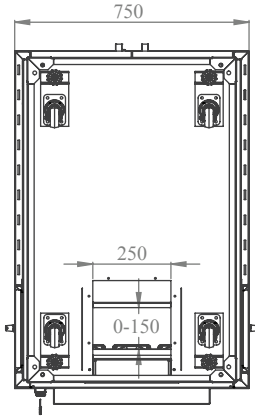

BOTTOM VIEW

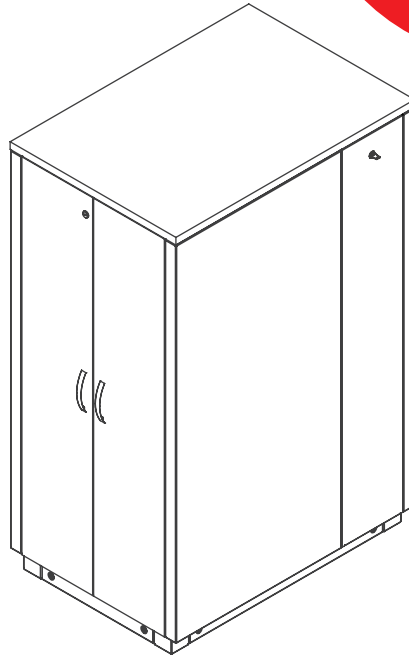

ISOMETRIC VIEW

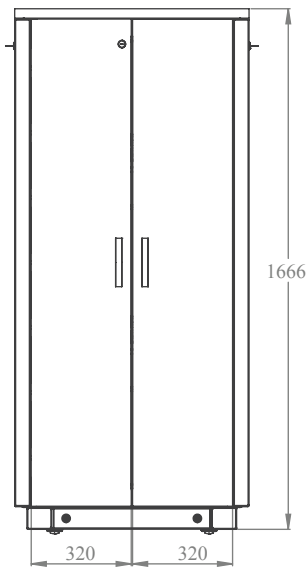

FRONT VIEW

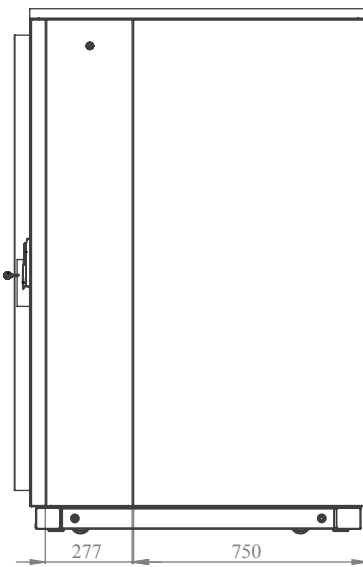

SIDE VIEW

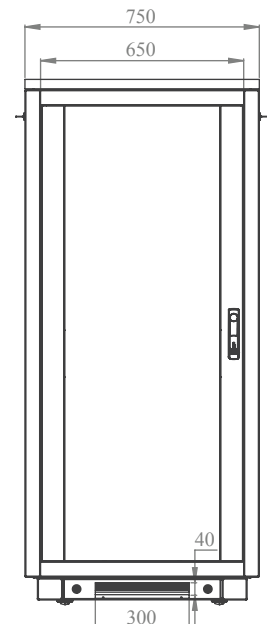

REAR VIEW

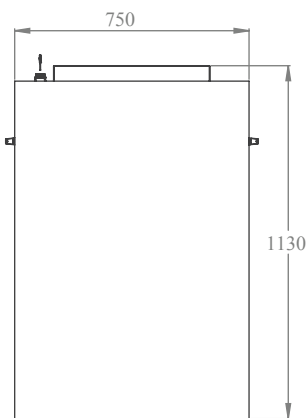

TOP VIEW

DRAWINGS

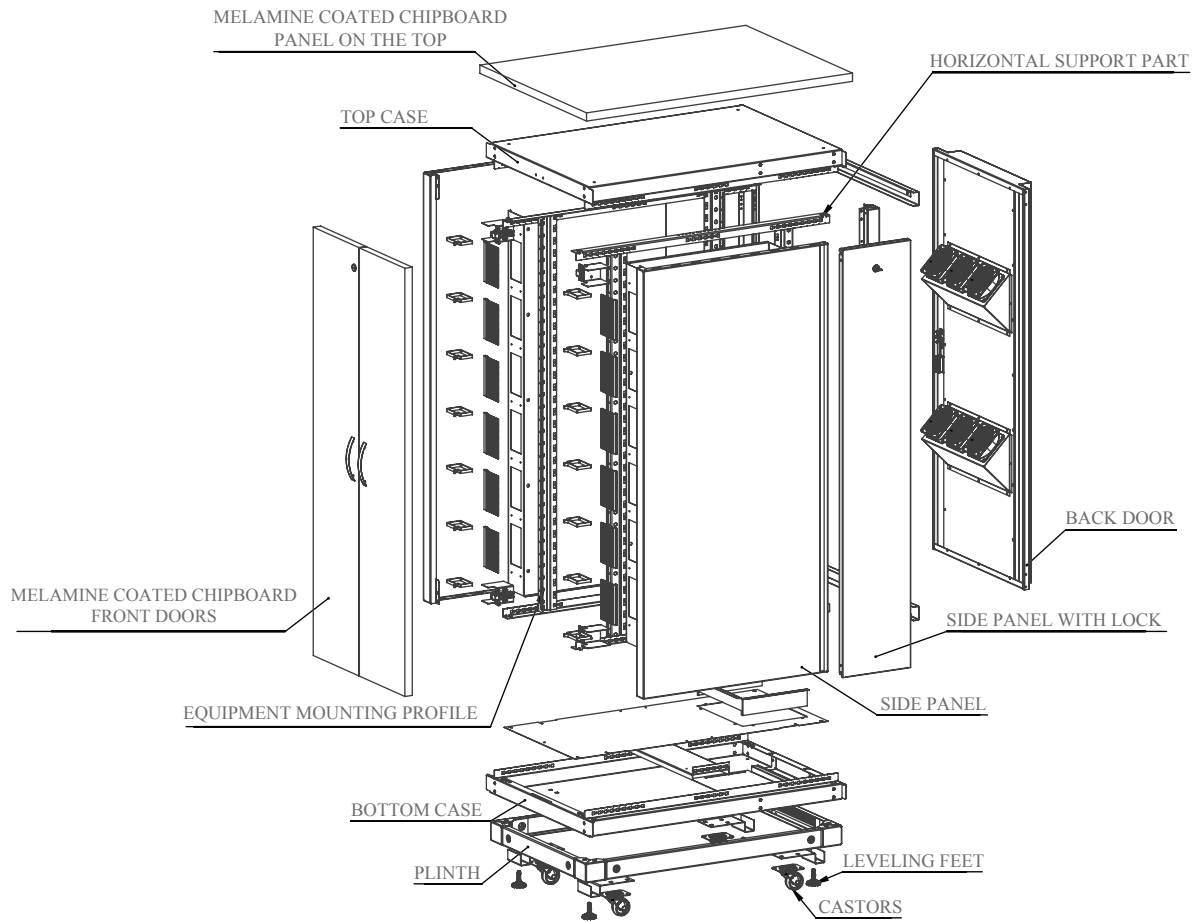

EXPLODED VIEW

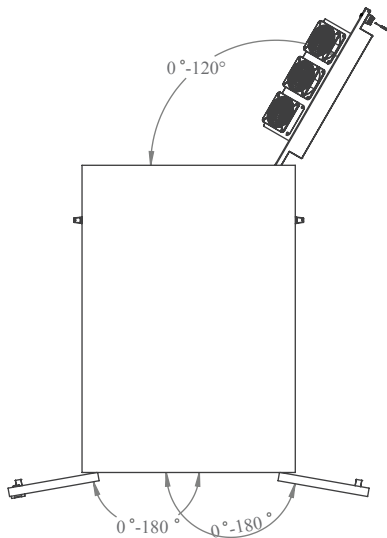

FRONT DOOR
OPENING ANGLE

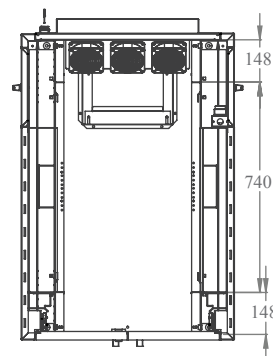

EQUIPMENT MOUNTING
DISTANCE

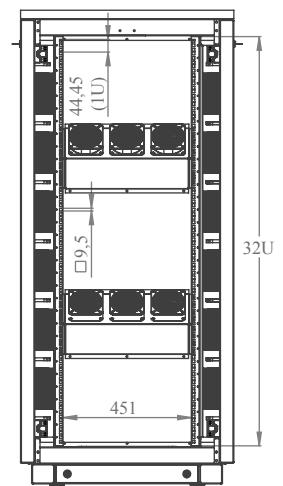

DIMENSIONS IN
WIDTH AND HEIGHT

19" SOUNDproof Free Standing Cabinets 32U

Width: 750 mm.
Depth: 1130 mm.

DRAWINGS

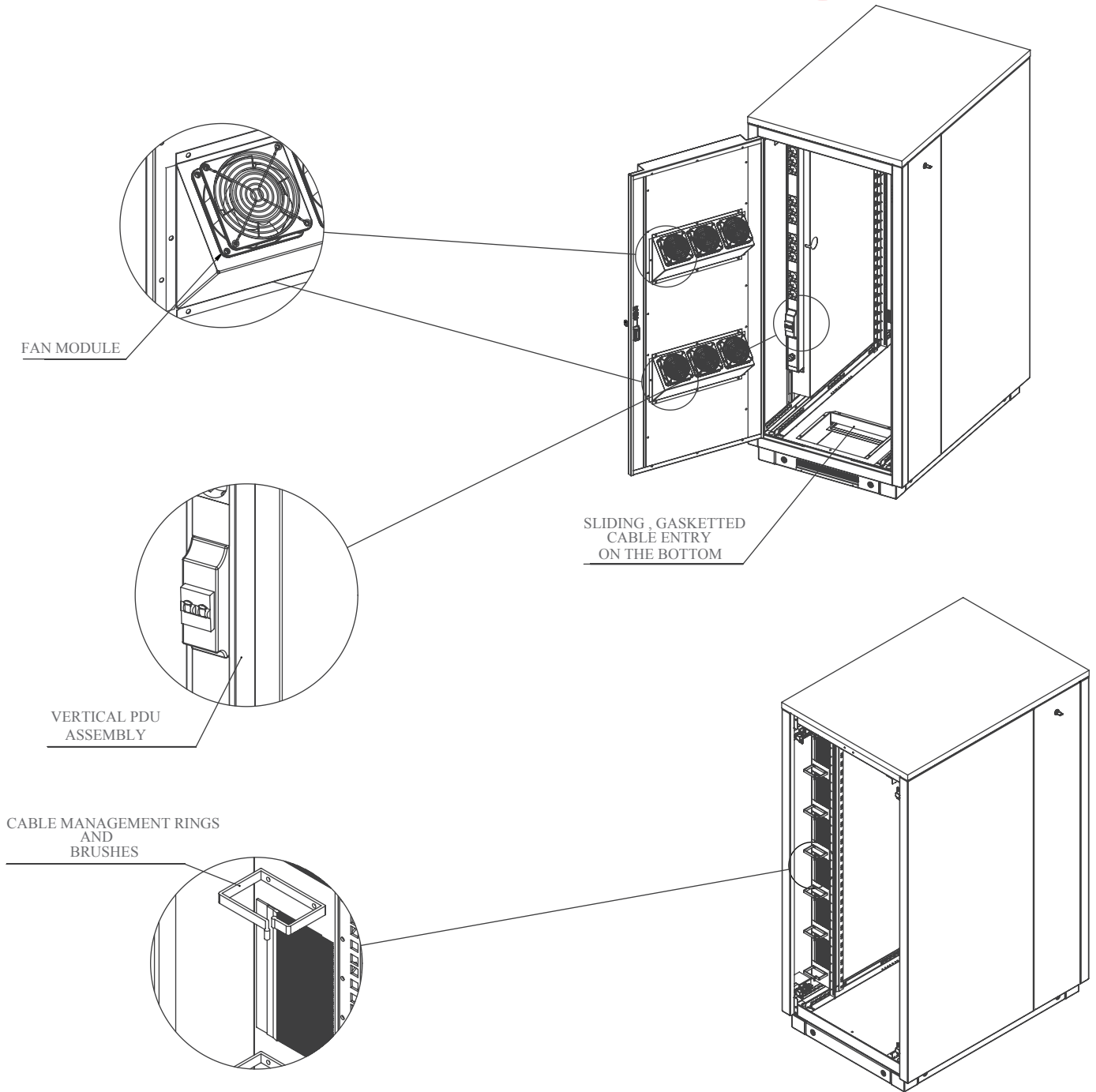

SOUNDproof Series Free Standing 19" Cabinets 32U W=750mm D=1130mm

Product Number	Product Description	Size W X D X H mm	h size in U	h in mm	H mm, overall incl feet, castor and plinth	Width Overall mm	Width Rail to Rail	Depth Overall mm	Depth Shipping Conf. Rail to Rail mm	QTY IN PACKAGE	PACKING DIMENSIONS W X D X H mm	Standard NET Weight of product kgs	Gross Weight of Product kgs	QTY IN PALETTE
LN-SP-32U7511-M-BL	32U 19" SOUNDproof Cabinet W=750mm D=1130mm	750x1130x1666	32U	1423	1666	750	19"	1130	740	1	820x1200x1787	165	183	1

* Standard supply is with M-Maple Wood / Furniture Concept

** Incase Requested with any other Wood/Furniture Concept , replace M with, O-Oak, C-Cherry,B- Beech, T-Teak, W-Walnut, based on your selection

*** All Metallic Parts are in RAL 9005 Black Color, any other color requests, please have a correspondence.



DRAWINGS

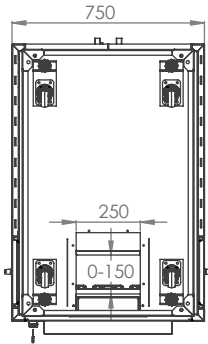

BOTTOM VIEW

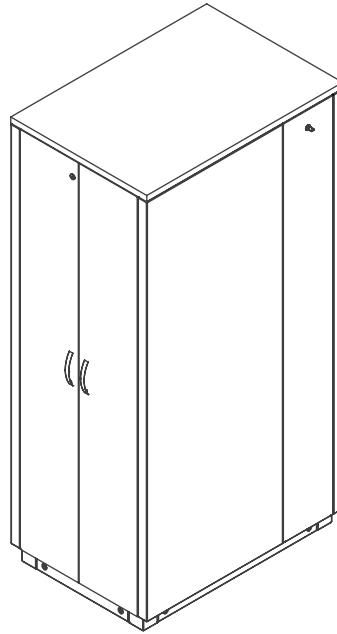

ISOMETRIC VIEW

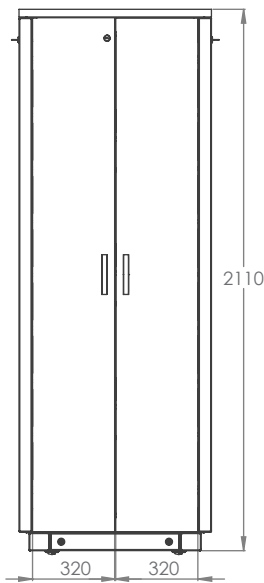

FRONT VIEW

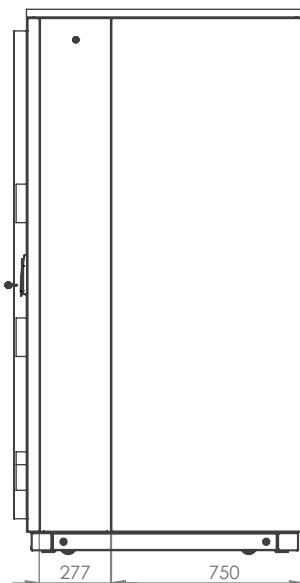

SIDE VIEW

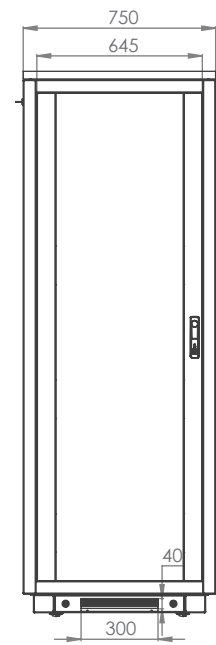

REAR VIEW

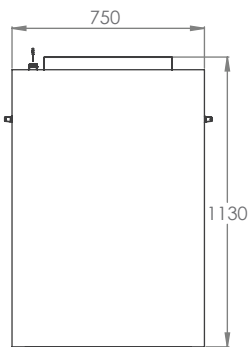

TOP VIEW

DRAWINGS

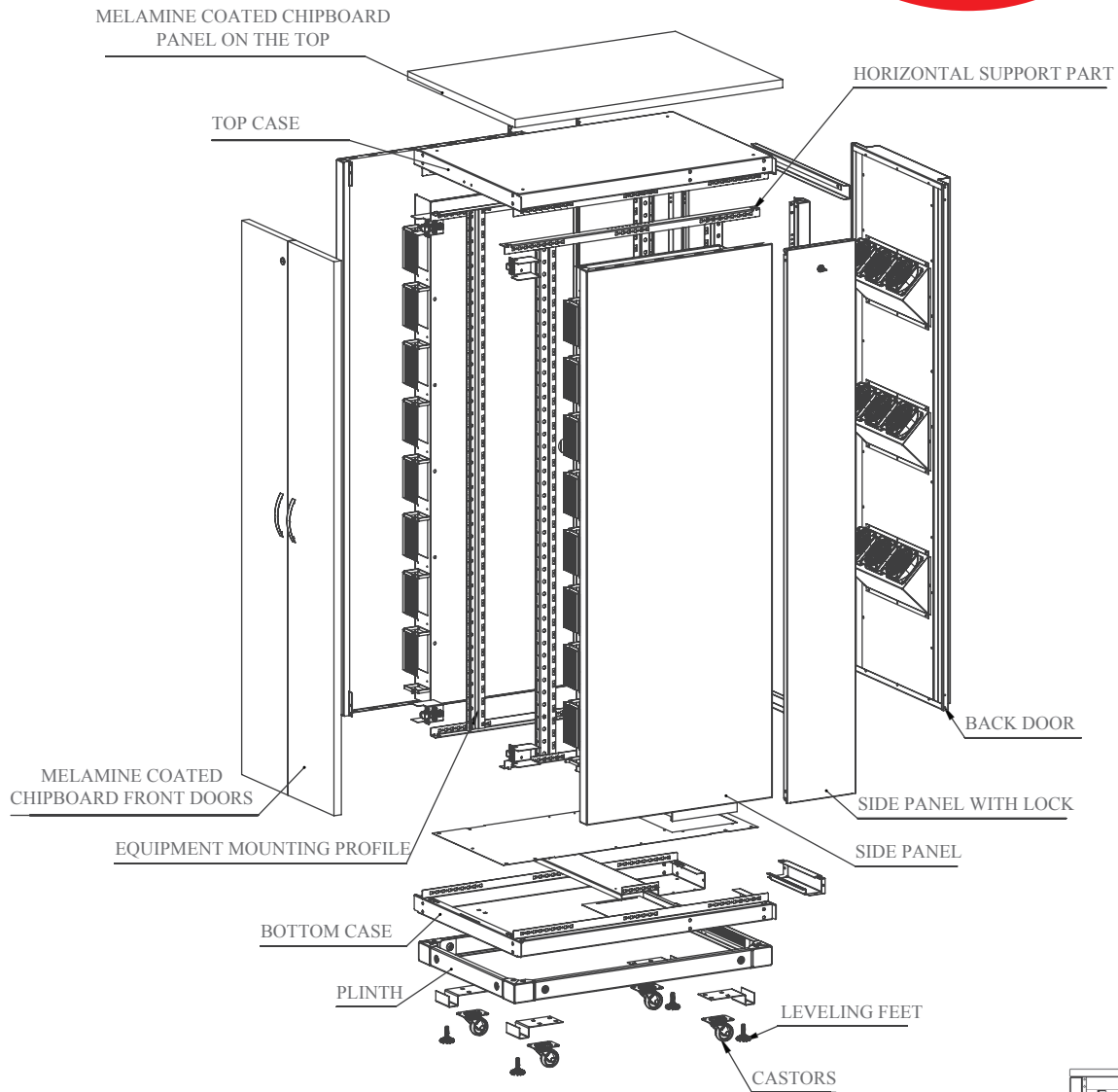

EXPLODED VIEW

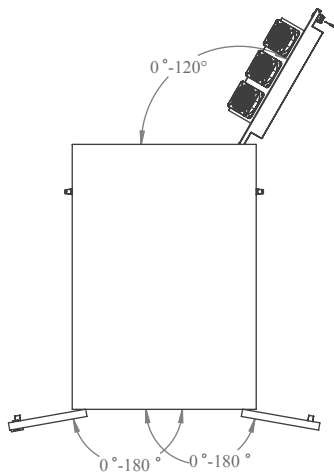

FRONT DOOR
OPENING ANGLE

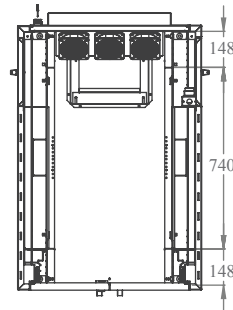

EQUIPMENT
MOUNTING DISTANCE

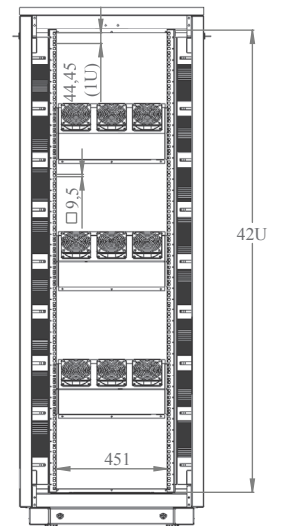

DIMENSIONS IN
WIDTH AND HEIGHT

DRAWINGS

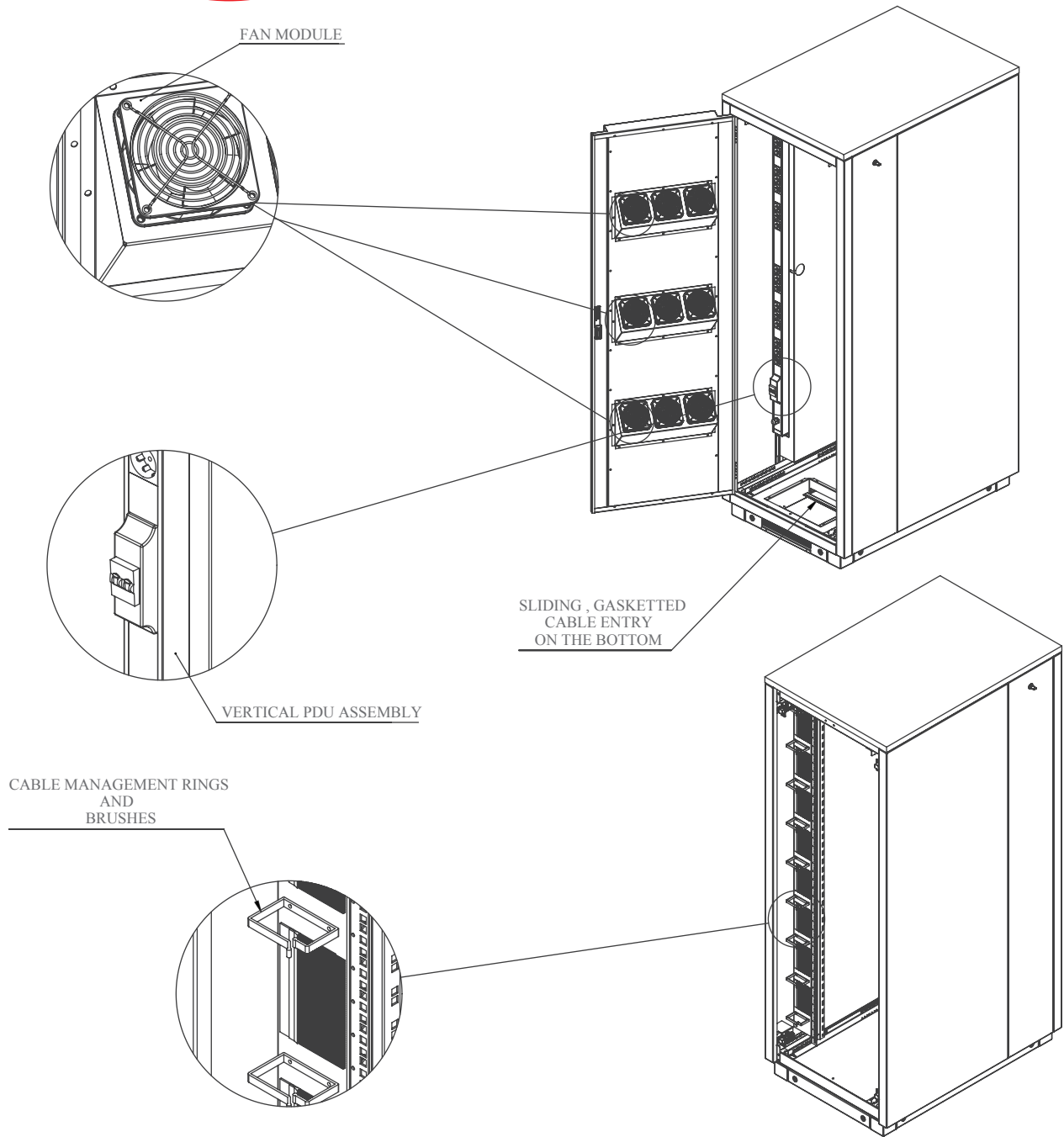

SOUNDproof Series Free Standing 19" Cabinets 42U W=750mm D=1130mm

Product Number	Product Description	Size WxDXH mm	h size in U	h in mm	H mm, overall incl feet, castor and plinth	Width Overall mm	Width Rail to Rail 19"	Depth Overall mm	Depth Shipping Conf: Rail to Rail mm	QTY IN PACKAGE	PACKING DIMENSIONS WxDXH mm	Standard NET Weight of product kgs	Gross Weight of Product kgs	QTY IN PALETTE
LN-SP-42U7511-M-BL	42U 19" SOUNDproof Cabinet W=750mm D=1130mm	750x1130x2110	42U	1867	2110	750	19"	1130	740	1	820x1200x2231	210	228	1

* Standard supply is with M-Maple Wood / Furniture Concept

** Incase Requested with any other Wood/Furniture Concept , replace M with, O-Oak, C-Cherry,B- Beech, T-Teak, W-Walnut, based on your selection

*** All Metallic Parts are in RAL 9005 Black Color, any other color requests, please have a correspondence.

Frequent Used Accesories SOUNDproof Cabinets

	17U	32U	42U
Fixed Shelves Universal Mutivendor	LN-RAF-SBT-D100-BL-UNV	LN-RAF-SBT-D100-BL-UNV	LN-RAF-SBT-D100-BL-UNV



Frequent Used Accesories SOUNDproof Cabinets

	17U	32U	42U
Heavy Duty Fixed Shelves	LN-RAF-SBA-D100-BL	LN-RAF-SBA-D100-BL	LN-RAF-SBA-D100-BL

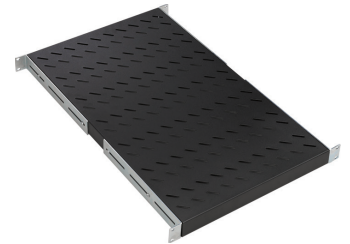

Frequent Used Accesories SOUNDproof Cabinets

	17U	32U	42U
Heavy Duty Sliding Shelves	LN-RAF-HRA-D100-BL	LN-RAF-HRA-D100-BL	LN-RAF-HRA-D100-BL

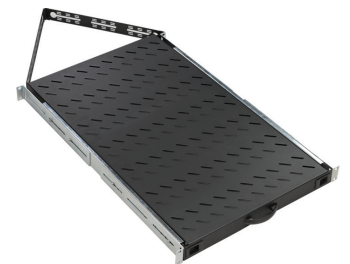

Frequent Used Accesories SOUNDproof Cabinets

	17U	32U	42U
Horizontal Cable Management Panel 19" 1U 5 rings	LN-KDG-YKD-1UKN-BL	LN-KDG-YKD-1UKN-BL	LN-KDG-YKD-1UKN-BL

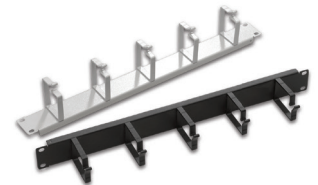

Frequent Used Accesories SOUNDproof Cabinets

	17U	32U	42U
Mounting Hardware, Fixing M6 Cage nut set of 20	LN-DGR-KFS-M620-XX	LN-DGR-KFS-M620-XX	LN-DGR-KFS-M620-XX



Frequent Used Accesories SOUNDproof Cabinets

	17U	32U	42U
Fan Modules max 30dB low Noise with Thermostat	3 Fans with Thermostat included in shipping	6 Fans with Thermostat included in shipping	6 Fans with Thermostat included in shipping
Plinth H70mm	included	included	included
Castor Set	included	included	included
Leveling Feet Group	included	included	included
Cable Management Panel and Rings	included	included	included



*** There are various type other accessories can be integrated to Soundproof Cabinets, please see various model compatible rack mount accessories in main catalogue accessries section.

19" SOUNDproof Cabinets / Accessories



Frequent Used Accesories SOUNDproof Cabinets

	17U	32U	42U
6xDIN49440 Socket Schuko Power Stripe, 19" 1U, aluminium housing, 1x16A cct breaker, 4000 Watt, 250V AC, 3x1.5mm2, 2,5m cable, DIN 49441 plug, CE approval	LN-PRZ-SGT-1U6P-SC (max 2 pcs)	LN-PRZ-SGT-1U6P-SC (max 4 pcs)	LN-PRZ-SGT-1U6P-SC (max 4 pcs)



Frequent Used Accesories SOUNDproof Cabinets

	17U	32U	42U
6xIEC 320 C13 Socket Power Stripe, 19" aluminium housing, 1x16A cct breaker, 4000 Watt, 250V AC, 2,5m cable, DIN 49441 plug, CE approval	LN-PRZ-SGT-1U6P-IE (max 2 pcs)	LN-PRZ-SGT-1U6P-IE (max 4 pcs)	LN-PRZ-SGT-1U6P-IE (max 4 pcs)



Frequent Used Accesories SOUNDproof Cabinets

	17U	32U	42U
6xBS1363 UK Socket Power Stripe, 19" 1,5U, aluminium housing, 16A lighted on/off switched, 4000 Watt, 250V AC, 3x1.5mm2, 2,5m cable, 13A BS1363 plug, CE approval	LN-PRZ-ONF-1U6P-UK (max 2 pcs)	LN-PRZ-ONF-1U6P-UK (max 4 pcs)	LN-PRZ-ONF-1U6P-UK (max 4 pcs)



Frequent Used Accesories SOUNDproof Cabinets

	17U	32U	42U
6xDIN49440 Socket Schuko Surge Protection power Stripe, 19" 1U, aluminium housing, 16A lighted on/off switched, 4000 Watt, 250V AC, 3x1.5mm2, 2,5m cable, DIN 49441 plug, CE approval	LN-PRZ-AKK-1U6P-SC (max 2 pcs)	LN-PRZ-AKK-1U6P-SC (max 4 pcs)	LN-PRZ-AKK-1U6P-SC (max 4 pcs)



Frequent Used Accesories SOUNDproof Cabinets

	17U	32U	42U
6xIEC 320 C13 Socket PDU with Ampermeter Display, 19" 1U, aluminium profile frame, 1x16A MCB, 4000 Watt, 250V AC, 3x2.5mm2, 3m cord with IEC60309 plug (16A 2P+E), CE mark	LN-PRZ-AMP-1U6P-IE (max 2 pcs)	LN-PRZ-AMP-1U6P-IE (max 4 pcs)	LN-PRZ-AMP-1U6P-IE (max 4 pcs)

19" SOUNDproof Cabinets / Accessories



Frequent Used Accesories SOUNDproof Cabinets			
	17U	32U	42U
6xDIN49440 Socket Schuko Power Stripe, 19" 1U, aluminium housing, 1x16A cct breaker, 4000 Watt, 250V AC, 3x1.5mm2, 2,5m cable, DIN 49441 plug, CE approval	LN-PRZ-SGT-1712-SC (max 2 pcs)	-	-
12xIEC 320 C13 Socket Schuko Power Stripe – double circuit (9+9), aluminium housing, 2pcs. 1x16A cct breaker, 250vac, for 17U cabinet height, no cable, ready cable connection point.	LN-PRZ-SGT-1712-IE (max 2 pcs)	-	-
16xDIN49440 Socket Schuko Power Stripe – double circuit (9+9), aluminium housing, 2pcs. 1x16A cct breaker, 250vac, for 32U cabinet height, no cable, ready cable connection point.	-	LN-PRZ-SGT-3216-SC (max 2 pcs)	-
16xIEC 320 C13 Socket Schuko Power Stripe – double circuit (9+9), aluminium housing, 2pcs. 1x16A cct breaker, 250vac, for 32U cabinet height, no cable, ready cable connection point.	-	LN-PRZ-SGT-3216-IE (max 2 pcs)	-
18xDIN49440 Socket Schuko Power Stripe – double circuit (9+9), aluminium housing, 2pcs. 1x16A cct breaker, 250vac, for 32U cabinet height, no cable, ready cable connection point.	-	-	LN-PRZ-SGT-4218-SC (max 2 pcs)
18xIEC 320 C13 Socket Schuko Power Stripe – double circuit (9+9), aluminium housing, 2pcs. 1x16A cct breaker, 250vac, for 32U cabinet height, no cable, ready cable connection point.	-	-	LN-PRZ-SGT-4218-IE (max 2 pcs)



Frequent Used Accesories SOUNDproof Cabinets			
	17U	32U	42U
24xIEC 320 (20xC13 + 4xC19) Socket PDU with Ampermeter Display, ZeroU, aluminium profile frame, 2x16A MCB, 8000 Watt, 250V AC, 3x6.0mm2, 3m cord with IEC60309 plug (32A 2P+E), CE mark	-	-	LN-PRZ-AMP-DM24-IE



Frequent Used Accesories SOUNDproof Cabinets			
	17U	32U	42U
20xIEC 320 (16xC13 + 4xC19) Socket, MONITORED IP PDU with Ampermeter Display, ZeroU, aluminium profile frame, 2x16A MCB, 8000 Watt, 250V AC, 3x6.0mm2, 3m cord with IEC60309 plug (32A 2P+E) ,CE mark, daisy-chain function upto 10 units, Remote Monitoring port	-	-	LN-PRZ-IZP-DM20-IE
20xIEC 320 (16xC13 + 4xC19) Socket, Socket Based MANAGED IP PDU with Ampermeter Display, ZeroU, aluminium profile frame, 2x16A MCB, 8000 Watt, 250V AC, 3x6.0mm2, 3m cord with IEC60309 plug (32A 2P+E) ,CE mark, daisy-chain function upto 10 units, Remote Management port	-	-	LN-PRZ-YNP-DM20-IE

*** There are various type other accessories can be integrated to Soundproof Cabinets, please see various model compatible rack mount accessories in main catalogue accessories section.